

Product Information

Language	English
Nr.	292
Data	6/2019
Subject	NEW CHAINSAW GSH 40 / 400



our power, your passion

NEW CHAINSAW GSH 40 / 400



The new GSH 40 (EXTRA CE) and GSH 400 (EURO 5) chainsaws are powerful 38.9 cc chain saws capable of developing 2.3 HP / 1.7 kW. Targeted at the entry-level user, they incorporate special technical solutions - primer, on/off lever/multi-function choke, aluminium oiler, hybrid antivibration system (3 springs + 2 rubber mounts), "EasyOn" - which enhance their quality, cutting performance and compliance with anti-pollution legislation, particularly in the GSH 400 (EURO 5) version with catalytic muffler.

These compact chain saws are designed incorporating the technology used in higher power models: they guarantee the best possible performance in conditions of the maximum comfort and safety. Occasional minor pruning tasks or cutting small diameter firewood can be carried out using practical and easy-to-use tools.

Performance and Plus Points

- **38.9 cm³ 2-stroke engine:** available in EURO 5 version (with catalytic converter) for the European market and version for non-EU markets (EXTRA CE).
- **Engine with 2 piston rings, forged and machined steel crankshaft, needle roller bearings, and nickel plated cylinder** to guarantee constant efficiency over time, also in the case of heavy-duty use.
- **Nylon filter:** longer working time between filter cleaning operations thanks to the large filtration surface.
- **Lateral chain tensioner:** simplifies tensioning adjustments while avoiding any risk of contact with the chain.
- **Adjustable aluminium oil pump:** facilitates the operator's job by allowing the oil feed to be adjusted to suit the workload on the tool and the bar/chain combination. Zero oil flow with the engine at idling speed ensures lower consumption and reduced environmental impact.

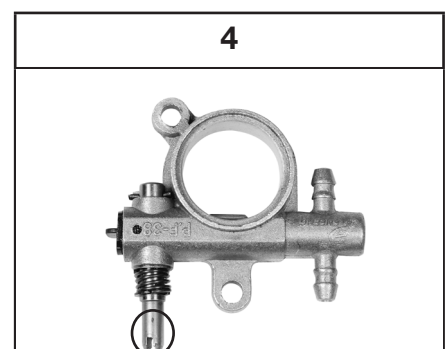
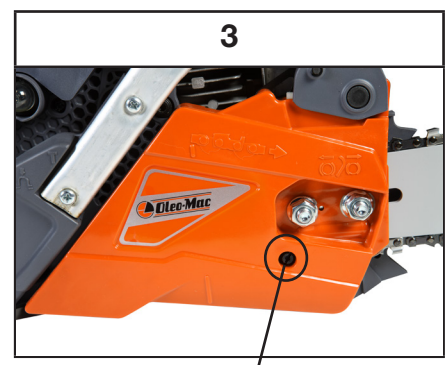
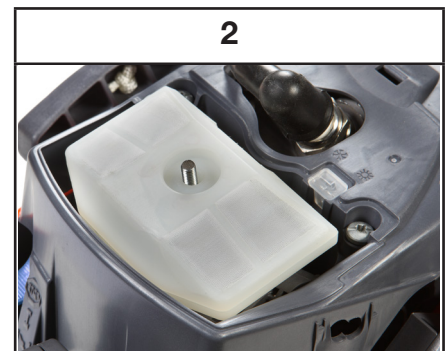

Performance and Plus Points

- **Anti-vibration system:** composed of 3 spring dampers and 2 rubber stops located between the handle and the engine frame to guarantee that the operator is completely isolated from vibration for greater comfort.
- **Single multifunction lever:** incorporates on/off switch, choke and half-throttle lock button for practicality and ease of use.
- **Ice device system:** allows work to be continued without problems even at low temperatures (below 0°C) by diverting the warm air flow from the cylinder towards the air filter to prevent ice formation.
- **Easy servicing:** filter cover with knob allows rapid and tool-free access to the "Ice device" system, inspection and replacement of the air filter, and access to the spark plug.
- **"EasyOn":** reduced kick-back easy starting system.

5

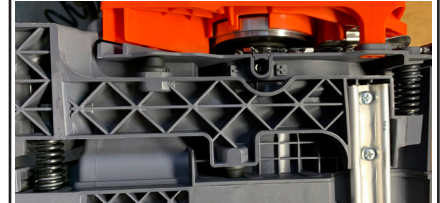

6



7



8

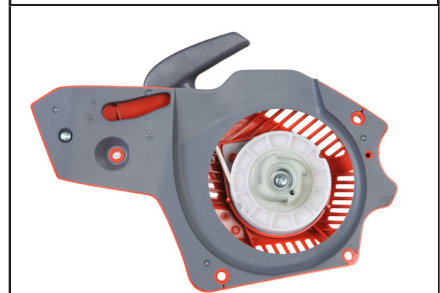



our power, your passion

MODEL	OM	GSH 40	GSH 400
ENGINE			
TYPE		2 tempi Emak (EXTRA CE)	2 tempi Emak (EURO5)
DISPLACEMENT	cm ³	38,9	
BORE x STROKE	mm x mm	40 x 31	
MAX POWER	HP/kW (rpm)	2,3 / 1,7	
MAX TORQUE	Nm (rpm)	2,04 Nm (6000 RPM)	
IDLE RPM	rpm	3,000	
MAX RPM AT NO LOAD	rpm	12,800	
FUEL CONSUMPTION (max power)	g/h (rpm)	880 gr/h a 8500 RPM	
IGNITION SYSTEM			
TYPE		Electronic	
COIL		Analog	
SPARK PLUG		TORCH L8RTF	
ICE DEVICE SYSTEM		Yes	
EASY ON SYSTEM		Yes	
FUEL AND LUBRIFICATION SYSTEM			
CARBURETOR		Ruixing	
AIR FILTER		Nylon	
FUEL		Mix 4% with PROSINT 2% (50:1) oil	
FUEL TANK CAPACITY	l	0.32	
PRIMER		Yes	
TRANSMISSION SYSTEM			
TRANSMISSION		Pinion	
CLUTCH		Centrifugal (4200 rpm clutch engagement)	
PINION TEETH (N°)		6	
SAFETY			
NOISE PRESSURE (L _{PA} av EN 11681-1, EN 22868)	dB(A)	103,2	
NOISE POWER (L _{WA} 2000/14/EC, EN 22868, EN ISO 3744)	dB(A)	111,5	
VIBRATION LEVEL (EN 11681-1, EN 22867, EN 12096)	m/s ²	6.9 (LH) – 7,1 (RH)	
UNCERTAINTY (EN 12096)	m/s ²	1.9 (LH) – 1.9 (HX)	
ERGONOMICS			
FRONT HANDLE		Plastic	
REAR HANDLE		Ergonomic	
ANTIVIBRATION SYSTEM		N°3 spring + N°2 rubber absorbers	
CUTTING SYSTEM			
BAR LENGHT	cm (inch)	35 - 41 (14" - 16")	41 (16")
CHAIN PITCH / GAUGE	inch x inch	3/8" x .050" Special	3/8" x .050" Special .325" x .050" Microlite
CHAIN BRAKE		Inertial	
OIL TANK VOLUME	l	0.22	
OIL PUMP		Automatic and adjustable	
CHAIN TENSIONER		Lateral	
HOOK		Plastic and steel	
HOMOLOGATIONS			
WEIGHT (Without cutters and bar)	kg	4,5	
WEIGHT POWER RATIO	kg/kW	2,7	



It's an **Emak S.p.A.** trademark
42011 Bagnolo in Piano (RE) Italy
www.myoleomac.com
www.youtube.com/MyOleoMac
www.facebook.com/OleoMacItalia
www.instagram.com/OleoMacItalia