

Product Information

Language	INGLESE
Nr.	155
Date	11/2009
Subject	WP 30 - WP 300



our power, your passion

NEW WP 30 - WP 300 WATER PUMPS



WP 30 (Euro 1)

WP 300 (Euro 2)



The new WP 30 - WP 300 self-priming water pumps are ideal for:

- small jobs around the home and garden
- filling ponds
- draining cellars
- watering the garden
- cleaning swimming pools

and for more intensive operations which require continuous use of the pump, such as watering lawns and vegetable plots.

Its design and compact shape are intended to facilitate transport, positioning and starting of the machine in various usage situations. The water pump incorporates a number of engineering solutions which are designed to make it simple to operate.

The new, professional-grade pump casing in aluminium is resistant to accidental knocks and corrosion, affording long-term durability and exceptional reliability.

The 30.5 cm³ engine has been designed to respect the environment. The Euro 2 version (mod. WP 300) minimises pollution and cuts emissions, resulting in extended running time between refuelling.

PERFORMANCE AND ENGINEERING SOLUTIONS

- **Emak 2-stroke Euro 2 engine with 30.5 cm³** displacement (also available in the EURO 1 version on the WP 30) produces 1.3 HP power. Easy starting and low fuel consumption are guaranteed by the digital coil (Fig. 1).

Fig. 1



- **Walbro WT 936 diaphragm carburettor:** ensures optimum operation and more stable combustion, even on uneven ground and support surfaces (Fig. 2).

Fig. 2



- **Muffler with catalytic converter and sound-absorbent material** (mod. WP 300 Euro 2) minimises unburned hydrocarbon emissions and helps to reduce the noise level of the machine (Fig.3).

Fig. 3



- **Aluminium pump casing:** corrosion and shock-resistant, assures outstanding long-term durability (Fig.4).

Fig. 4



- The **new engine** and **pump casing** make it possible to achieve a flow rate of 150 litres/minute and a maximum head of 36 metres.

EASE OF USE AND COMFORT

- **Multifunction control:** ON/OFF function and engine speed control integrated into a single knob; clearly visible, practical to operate and positioned at the top of the handgrip, making it easier to grasp (Fig. 5).



- **Simple starting:** Primer, air lever and flow adjustment (engine speed) control are grouped together in one place to facilitate starting and adjustment of the flow rate (Fig. 6).



- The **ergonomic shape** of the filler plug and the raised position of the tank inlet facilitate refuelling.

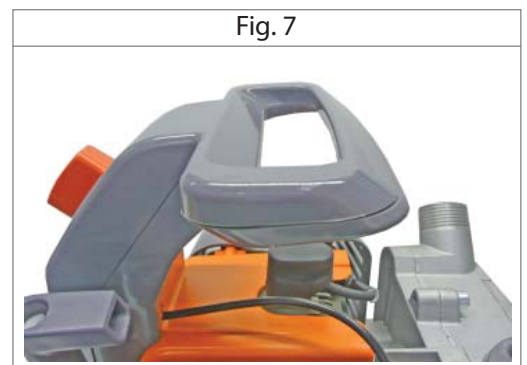

- **Transport handle:** the ergonomic shape ensures a comfortable grip (even when wearing gloves); due to the position of the handle, which is built into the pump casing, the weight of the pump is evenly distributed during transport, making positioning and storage more convenient (Fig. 7).

- **Generously sized support foot:** lends stability to the pump and, cushioned by 4 rubber mounts, helps to dampen vibration generated by the engine (Fig. 8).

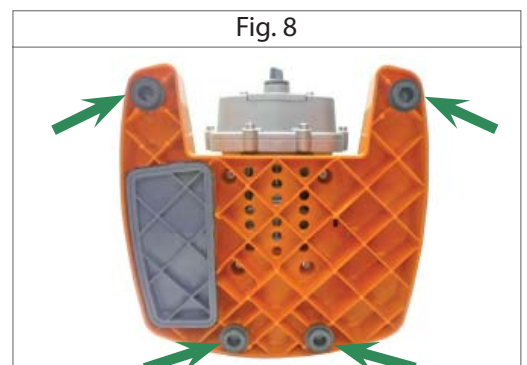

EASY MAINTENANCE

- **Inspectable pump casing:** by removing the 4 screws the impeller and pump casing can be inspected, cleaned and serviced in no time. (Fig. 9)

- **The snap-fit filter cover** opens without the use of tools, affording straightforward access to the air filter. (Fig. 10)

- **Quick pump** charging and discharging via the pipes located on the pump casing; no tools needed to unscrew the plugs. (Fig. 11)

- **Available accessories:**

- | | |
|--|--------------|
| A) 1" fittings kit (standard issue) | p/n 34000002 |
| B) Air filter with 1" fitting (standard issue) | p/n 34000001 |
| C) 1" spiral hose, length 4 m (optional) | p/n 34000031 |

Fig. 9

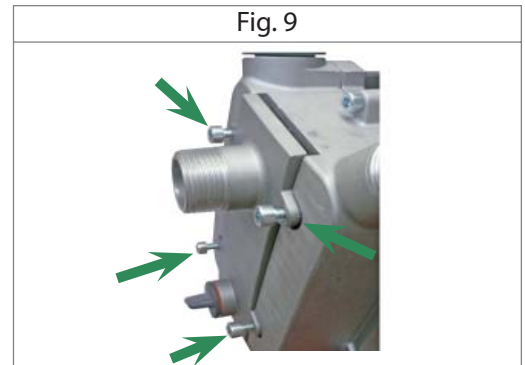

Fig. 10

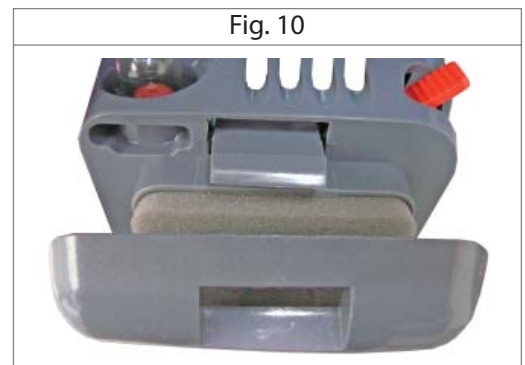

Fig. 11

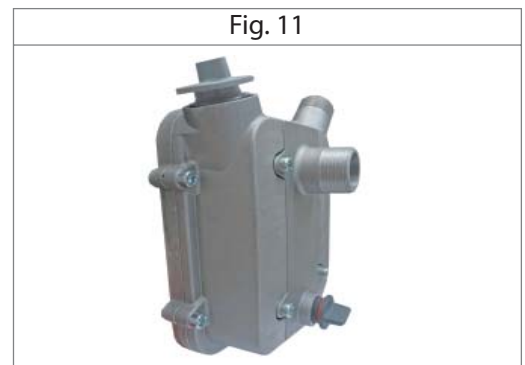
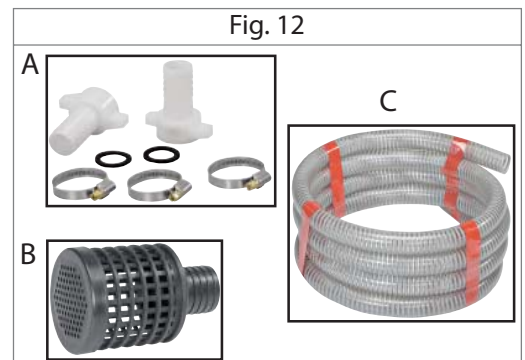
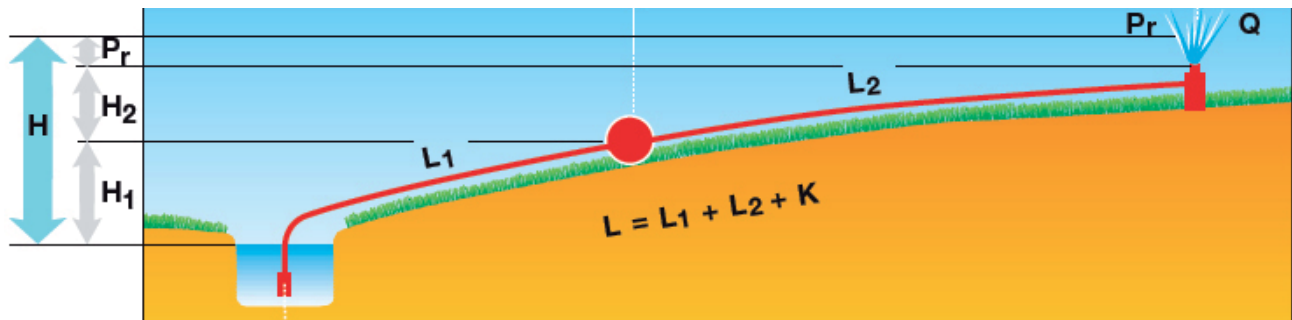

Fig. 12



CORRECTLY SIZING THE WATER PUMP



Calculate the equivalent length (L) of the tubing in metres.

$$L = L1 + L2 + K$$

L1 = length of tubing in metres from water to pump.

L2 = length of tubing in metres from pump to point of discharge.

K = head losses due to possible fittings.

Calculate the total head (H) in metres.

$$H = H1 + H2 + Pr$$

H1 = static suction head in metres between water surface and pump (maximum static suction head 7.5 m).

H2 = static discharge head between pump and point of discharge.

Pr = desired pressure expressed in metres at the point of discharge (1 bar = 10 m).

Total head H (m)							
1,5	3	5	10	15	20	25	30

Total length of pipeline Ø 25 mm	5	137	132	128	124	108	98	72	57
	20	108	104	100	89	76	63	57	41
	50	82	79	76	67	58	46	33	12
	100	62	60	57	50	43	34	25	10
	200	46	44	42	37	32	25	16	
	500	28	27	25	22	20	15		

L (m)	Flow rate Q (L/min)
-------	---------------------

TECHNICAL DATA

Model		WP 30	WP 300
Engine			
Type		Emak 2-stroke EURO 1	Emak 2-stroke EURO 2
Displacement	cm ³	30,5	
Bore x Stroke	mm x mm	36 x 30	
Maximum power output	HP/kW	1,3 - 1	
Maximum torque	Nm (rpm)	1,12 (6000)	
Idling speed	rpm	5800 / 6200	
Hourly fuel consumption	g/h	450 (6000)	
Ignition system			
Type		Capacitive	
Spark plug		Champion RCJ 4	
Coil		Digital Walbro MB	
Fuel & Lubrication system			
Carburettor		Walbro WT 936	
Fuel		Mix 2%	
Fuel tank capacity	l	0,83	
Air filter		Spogne	
Primer		Yes	
Characteristic of the pump			
Type		Priming	
Delivery Ø (Suction Ø)	mm (inch)	25,4 (1")	
Max flow rate	l/min	150	
Max head	m (bar)	36 (3,6)	
Suction head	m	7	
Autonomy of work	h	1,5	
Safety			
Sound power 2000/14/EC LwA EN ISO 3744	dB(A)	102	
Type test approvals			
Weight	kg	5,5	
Power to weight ratio	kg/kW	5,5	
Dimensions	cm	31 x 28 x 33	



It's an Emak S.p.A. trademark Member of the Yama Group
 Via E. Fermi, 4 • 42011 Bagnolo in Piano (Reggio Emilia) Italy
 Tel. +39 0522 956611 • Fax +39 0522 951555
 info@myoleomac.com • www.myoleomac.com